



ZETA-85/C & ZETA-100/C

Low Pressure Diaphragm Pumps

ZETA-85/C and ZETA-100/C low pressure, 3-cylinder diaphragm pumps are excellent for various horticultural and agricultural spraying applications.

Simplicity of design and common parts allow easy and affordable maintenance. 1-3/8" male six-spline PTO shaft is standard. ZETA-100/C includes pulsation dampner.

ZETA-85/C and ZETA-100/C pumps have anodized aluminum bodies, coated aluminum heads and glass-filled nylon manifolds.

For industrial uses and spraying applications not listed, please consult UDOR U.S.A.

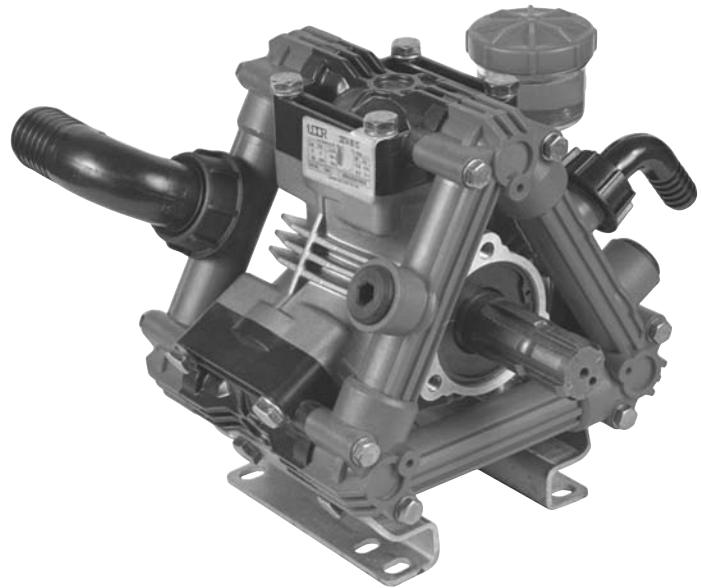

SPECIFICATIONS

| | |
|-------------------------------|-------------------------|
| Maximum Flow | |
| ZETA-85/C | 22 GPM |
| ZETA-100/C | 25 GPM |
| Maximum Pressure..... | 300 PSI |
| Maximum RPM | 540 RPM |
| Maximum Temperature | 140°F |
| Inlet Port (Hose Barb) | 1-1/2" |
| Outlet Port (Hose Barb) | 3/4" |
| Dimensions | L-10.5" x W-11" x H-12" |
| Weight | |
| ZETA-85/C..... | 32 lbs. |
| ZETA-100/C..... | 34 lbs. |
| Diaphragm Material..... | DESMOPAN |

NOTE - Protect pumps from freezing. If freezing conditions exist, flush pump and system with a 50/50 mixture of antifreeze and water.

ZETA-85/C & 100/C